

SPINNING REEL **8300A**

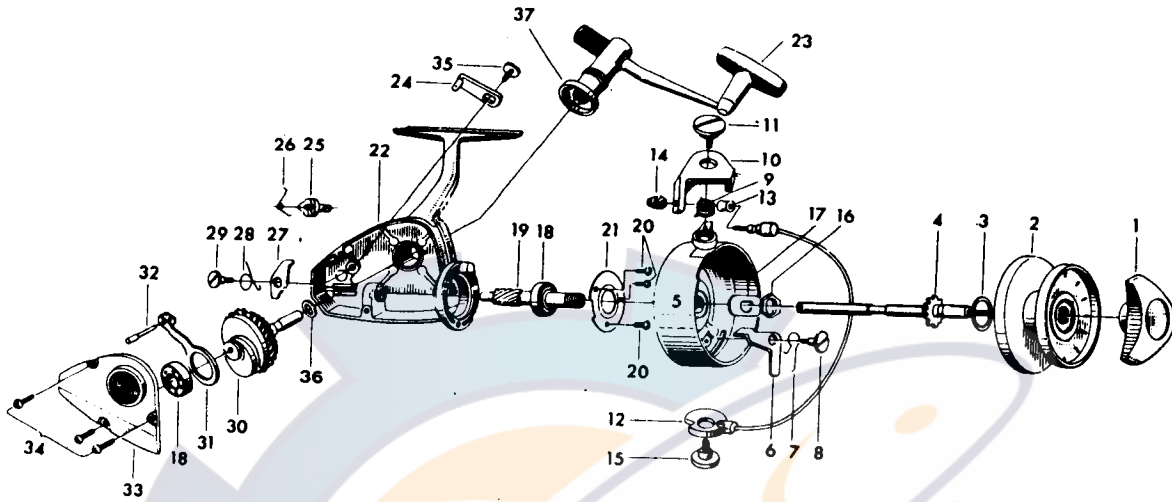

LINE CAPACITY: 200 YDS., 12 LB. TEST (200m Dia. 0.30mm)

Key No.	Parts No.	Parts Name	Key No.	Parts No.	Parts Name
1	60009021	Drag knob assembly	20	63516501	Ball bearing ret. washer screw
2	67305411	Spool assembly	21	66323601	Ball bearing ret. washer
3	63725713	Spool washer	22	60012811	Body
4	60008841	Main shaft assembly	23	67456611	Handle
5	60008541	Rotor	24	65404401	Anti-reverse lever
6	65704401	Bail kick lever	25	64604111	Anti-reverse cam
7	61405031	Bail kick lever spring	26	61417201	Anti-reverse cam spring
8	63612901	Bail kick lever screw	27	61104611	Anti-reverse claw
9	61416621	Bail spring	28	61416521	Anti-reverse claw spring
10	62304821	Arm lever	29	63613701	Anti-reverse claw screw
11	63613401	Arm lever screw	30	60008721	Drive gear
12	60008621	Bail	31	64804101	Oscillating slider
13	62501901	Line roller	32	61207201	Oscillating slider pin
14	63409101	Bail nut	33	60013002	Body cover
15	63613501	Bail holder screw	34	63516401	Body cover screw
16	63404601	Rotor nut	35	63501931	Anti-reverse lever screw
17	63724901	Rotor retaining washer	36	63712826	Drive gear washer
18	66317611	Ball bearing	37	66357102	Handle cover
19	64010042	Pinion			